

BYW95A - BYW96E

AVALANCHE FAST SOFT-RECOVERY RECTIFIER DIODES

PRV : 200 - 1000 Volts
Io : 3.0 Amperes

FEATURES :

- * High current capability
- * High surge current capability
- * High reliability
- * Low reverse current
- * Low forward voltage drop
- * Fast switching for high efficiency
- * Pb / RoHS Free

MECHANICAL DATA :

- * Case : DO-201AD Molded plastic
- * Epoxy : UL94V-O rate flame retardant
- * Lead : Axial lead solderable per MIL-STD-202, Method 208 guaranteed
- * Polarity : Color band denotes cathode end
- * Mounting position : Any
- * Weight : 1.16 grams

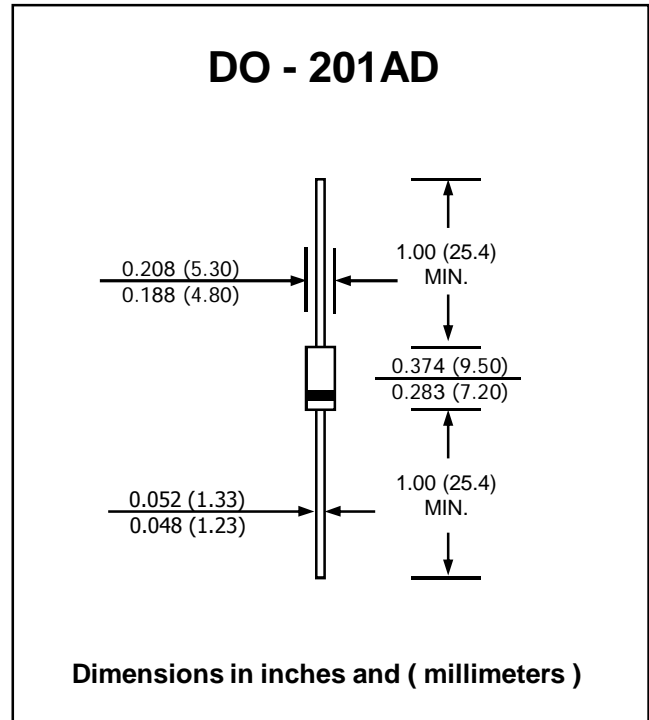

MAXIMUM RATINGS AND ELECTRICAL CHARACTERISTICS

Rating at 25 °C ambient temperature unless otherwise specified.
 Single phase, half wave, 60 Hz, resistive or inductive load.
 For capacitive load, derate current by 20%.

RATING	SYMBOL	BYW 95A	BYW 95B	BYW 95C	BYW 96D	BYW 96E	UNIT
Maximum Repetitive Peak Reverse Voltage	V_{RRM}	200	400	600	800	1000	V
Maximum Continuous Reverse Voltage	V_R	200	400	600	800	1000	V
Min. Reverse Avalanche Breakdown Voltage @ $I_R = 0.1$ mA	$V_{(BR)R-min}$	300	500	700	900	1100	V
Maximum Average Forward Current $T_{ip} = 60$ °C (Note 1)	$I_{F(AV)}$	3.0					A
Maximum Non-Repetitive Peak Forward Surge Current	I_{FSM}	70					A
Maximum Repetitive Peak Forward Current	I_{FRM}	15					A
Maximum Forward Voltage at $I_F = 5.0$ Amps.	V_F	1.5					V
Maximum Reverse Current at Reverse Voltage	I_R	5.0					μ A
Maximum Reverse Current at Reverse Voltage $T_j = 165$ °C	$I_{R(H)}$	150					μ A
Maximum Reverse Recovery Time (Note 2)	T_{rr}	250			300		ns
Thermal Resistance - Junction to Ambient	$R_{\theta JA}$	75					K / W
Junction Temperature Range	T_J	- 65 to + 175					°C
Storage Temperature Range	T_{STG}	- 65 to + 175					°C

Notes :

- (1) Lead Length 10 mm.
- (2) Measured with $I_F = 0.5A$, $I_R = 1.0A$, $I_{rr} = 0.25A$

RATING AND CHARACTERISTIC CURVES (BYW95A - BYW96E)

FIG.1 - REVERSE RECOVERY TIME CHARACTERISTIC AND TEST CIRCUIT DIAGRAM

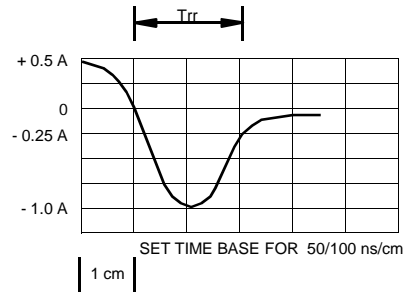
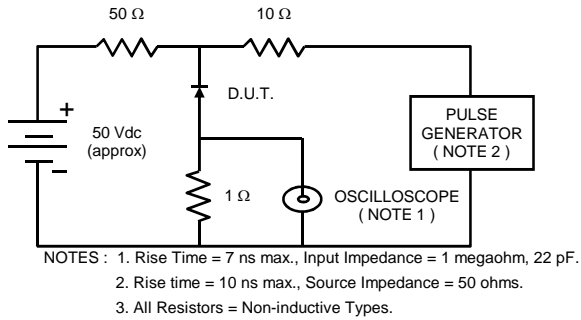

FIG.2 - DERATING CURVE FOR OUTPUT RECTIFIED CURRENT

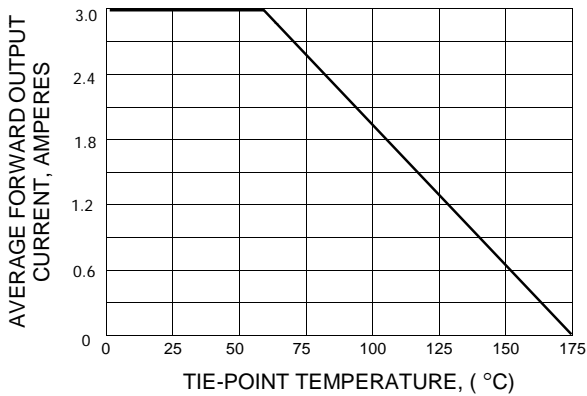

FIG.3 - MAXIMUM NON-REPETITIVE PEAK FORWARD SURGE CURRENT

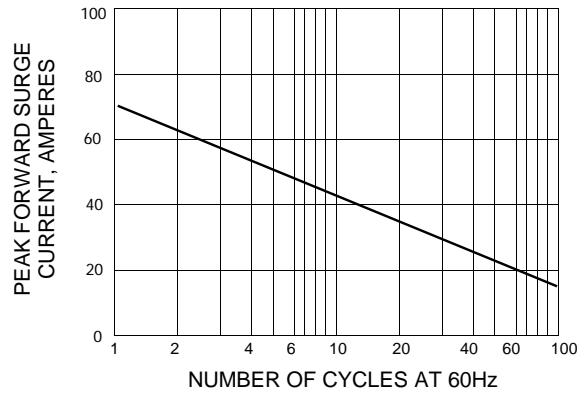

FIG.4 - TYPICAL FORWARD CHARACTERISTICS

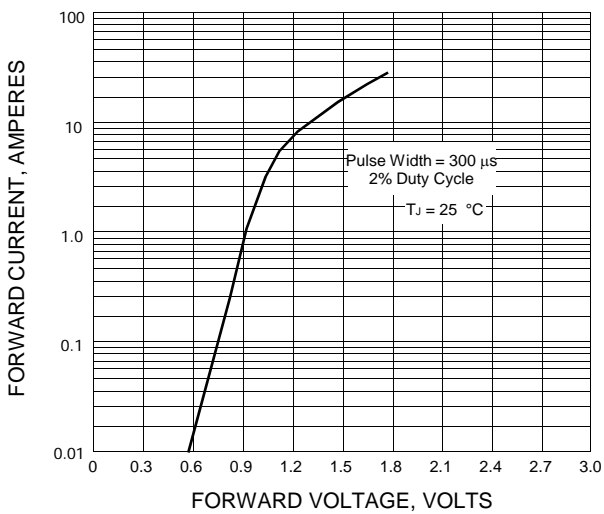

FIG.5 - TYPICAL REVERSE CHARACTERISTICS

